

## Custom Module Solution

DC Module 12, 24, or 48 LED board  
XMD-FBx-LLxA

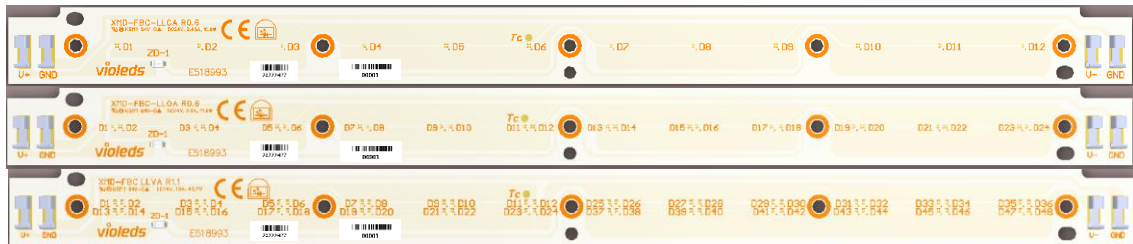

## Product Brief

### Description

- Utilizes DY9560 WICOP devices
- Designed for use with LEDiL VIOLET focusing optics

### Features and Benefits

- Lead free product
- Push-in connectors
- Can be used in daisy chain configuration
- UL Compliant: E518993
- CE Tested to Standards:
  - EN55105 : 2013
  - EN61547 : 2009
  - EN62031 : 2008 + A1: 2013 + A2: 2015
  - EN62741 : 2008

### Key Applications

- Horticulture
- Reptile lighting
- Surface disinfection
- Fluorescent spectroscopy
- Chemical and biological analysis

## Product Nomenclature

Table 1. Order Codes

Wavelength	LED Number	SVC Part number
UVB (future development)	12	XMD-FBB-LLCA
	24	XMD-FBB-LLOA
	48	XMD-FBB-LLVA
UVC	12	XMD-FBC-LLCA
	24	XMD-FBC-LLOA
	48	XMD-FBC-LLVA

## Nomenclature

# XMD-FBx-LLxA

XMD : SVC internal code  
 FB : Flat Board  
 x : Wavelength  
 F : SVC internal code  
 LL : Customer code  
 x : LED Number Code  
 A : Revision

C	UVC
B	UVB
C	12
O	24
V	48

---

## Table of Contents

Index	
• Product Brief	
• Product Nomenclature	
• Table of Contents	
• Performance Characteristics	
• Spectral Distribution	
• Mechanical Dimensions	
• Circuit Drawing	
• Wiring Guide	
• Part List	
• Label Information	
• Packing Introduction	
• Precaution for Use	
• Storage before use	
• Company Information	
• Revision History	

---

## Performance Characteristics

**Table 2. Electro Optical Characteristics at Nominal Current** ( $T_a=25^\circ\text{C}$ , RH=30%)

Part Number	$I_f$ (A)	Parameter	Symbol	Value			Unit
				Min	Typ	Max	
XMD-FBC-LLxA	Nom.	Peak Wavelength <sup>[1]</sup>	$\lambda_p$	270	275	280	nm
XMD-FBB-LLxA	Nom.			280	285	290	
XMD-FBx-LLCA	0.45	Radiant Flux <sup>[2,3]</sup>	$\Phi_e$	162	207	-	mW
XMD-FBx-LLOA	0.90			324	414	-	
XMD-FBx-LLVA	1.80			648	828	-	
XMD-FBx-LLxA	Nom.	Forward Voltage <sup>[4]</sup>	$V_f$	20	24	27	V
		Viewing Angle	$2\Theta_{1/2}$	-	>135	-	deg.

**Table 3. Maximum Ratings**

Part Number	Parameter	Symbol	Value			Unit
			Min	Typ	Max	
XMD-FBx-LLCA	Forward Current	$I_F$	-	0.45	0.6	A
XMD-FBx-LLOA			-	0.9	1.2	
XMD-FBx-LLVA			-	1.8	2.4	
XMD-FBx-LLCA	Power Dissipation	$P_d$	-	10.8	16.8	W
XMD-FBx-LLOA			-	21.6	33.6	
XMD-FBx-LLVA			-	43.2	67.2	
XMD-FBx-LLxA	Operating Temperature <sup>[5]</sup>	$T_J$	- 30	-	105	$^\circ\text{C}$
	Storage Temperature	$T_A$	- 40	-	100	$^\circ\text{C}$

**Notes :**

1. Peak wavelength measurement tolerance:  $\pm 3$  nm
2. Optical output power measurement tolerance:  $\pm 10\%$
3.  $\Phi_e$  is the optical output power as measured with an integrated sphere
4. Forward voltage measurement tolerance:  $\pm 3\%$
5.  $T_J$  is the junction temperature of the LED
6.  $T_J \approx T_c + \frac{22.8 \times P_d}{LED\#}$  where LED# is defined by LED Number Code on page 2

## Relative Spectral Distribution

Relative Spectral Distribution vs. Wavelength Characteristic, Ta=25 °C IF=nominal

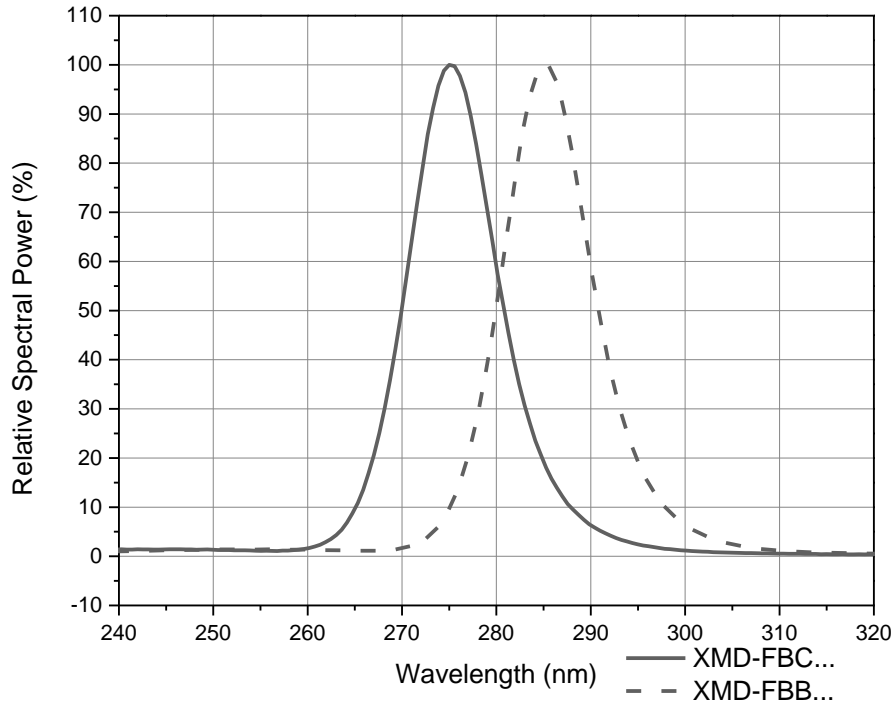

# Mechanical Dimensions

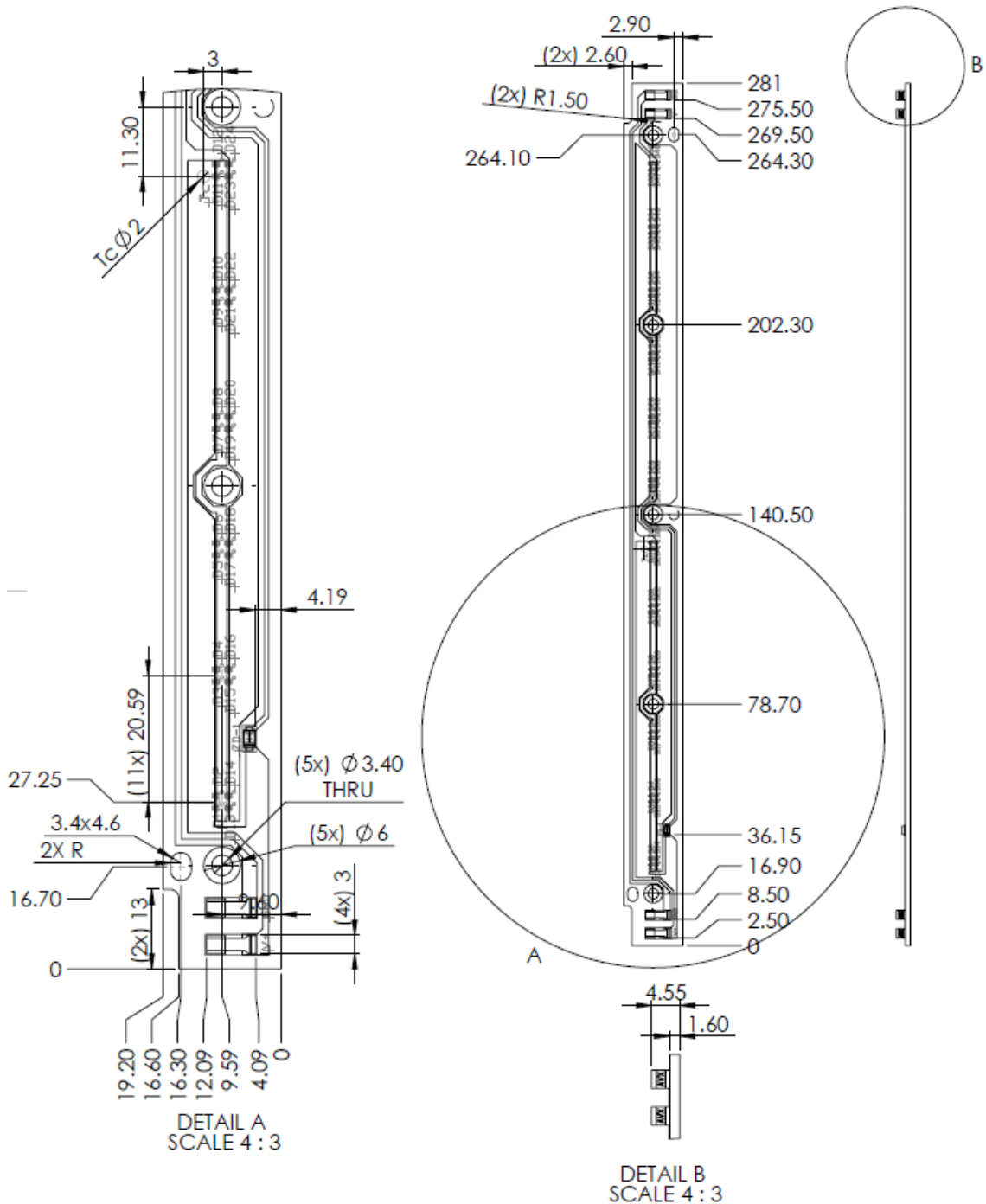

**Notes :**

- (1) All dimensions are in mm
- (2) For reference only
- (3) Not to scale

For 4 LED clusters – clusters on centerline  
 For 2 LED clusters – All LEDs on centerline  
 For 1 LED clusters – LED at cluster center  
 Recommended fasteners: M3 pan head

# Circuit Drawing

XMD-FBx-LLVA

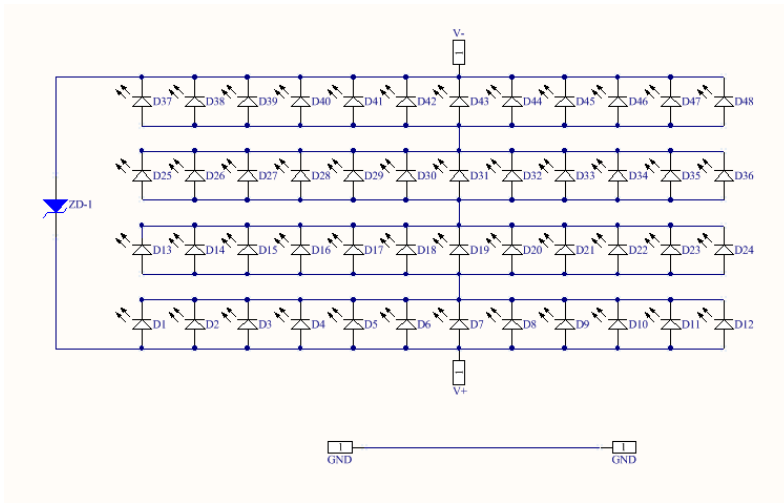

XMD-FBx-LLOA

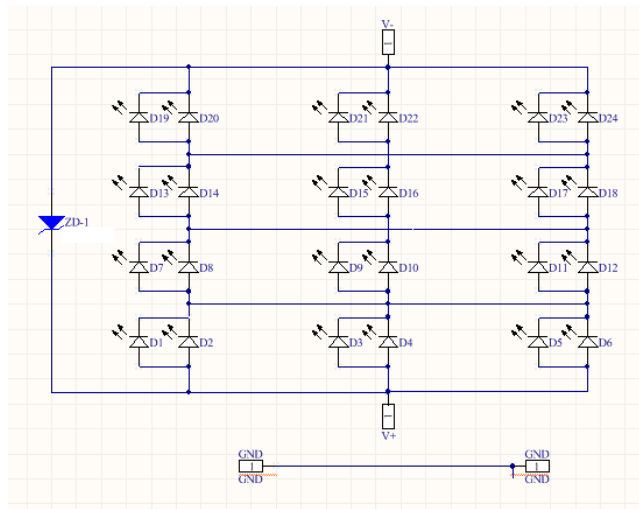

XMD-FBx-LLCA

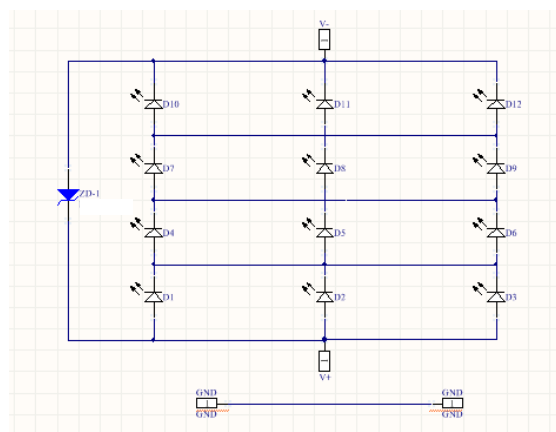

# Wiring Guide

**WARNING: DO NOT WIRE MORE THAN  
9 BOARDS IN SERIES**

Notes:

Recommended Wire: 18–26 AWG

## Single Board



For terminating end:  
V- to GND

## Multiple Boards

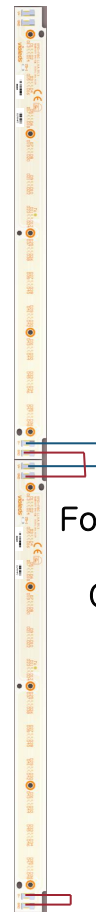

For all junctions:  
V- to V+  
GND to GND

For terminating end:  
V- to GND



## Part List

Table 4. Part List

No	Part	Reference	Specification	Quantity	
XMD-FBC-LLVA	1	LED PKG	D1~D48	DY9560-27 (<200mV binning)	48
	2	MCPCB	-	MCPCB 281mm x 19.2mm x 1.6mm (t)/ 1layers / Cu=2oz / White PSR / Yellow silk / OSP	1
	3	TVS	ZD-1	PTVS28VS1UR	1
	4	Connector	-	AVX_Interconnect-70-9296-001-003-006	4

No	Part	Reference	Specification	Quantity	
XMD-FBC-LLOA	1	LED PKG	D1~D24	DY9560-27(<200mV binning)	24
	2	MCPCB	-	MCPCB 281mm x 19.2mm x 1.6mm (t)/ 1layers / Cu=2oz / White PSR / Yellow silk / OSP	1
	3	TVS	ZD-1	PTVS28VS1UR	1
	4	Connector	-	AVX_Interconnect-70-9296-001-003-006	4

No	Part	Reference	Specification	Quantity	
XMD-FBC-LLCA	1	LED PKG	D1~D12	DY9560-27(<200mV binning)	12
	2	MCPCB	-	MCPCB 281mm x 19.2mm x 1.6mm (t)/ 1layers / Cu=2oz / White PSR / Yellow silk / OSP	1
	3	TVS	ZD-1	PTVS28VS1UR	1
	4	Connector	-	AVX_Interconnect-70-9296-001-003-006	4

No	Part	Reference	Specification	Quantity	
XMD-FBB-LLVA	1	LED PKG	D1~D48	DY9560-28(<200mV binning)	48
	2	MCPCB	-	MCPCB 281mm x 19.2mm x 1.6mm (t)/ 1layers / Cu=2oz / White PSR / Yellow silk / OSP	1
	3	TVS	ZD-1	PTVS28VS1UR	1
	4	Connector	-	AVX_Interconnect-70-9296-001-003-006	4

No	Part	Reference	Specification	Quantity	
XMD-FBB-LLOA	1	LED PKG	D1~D24	DY9560-28(<200mV binning)	24
	2	MCPCB	-	MCPCB 281mm x 19.2mm x 1.6mm (t)/ 1layers / Cu=2oz / White PSR / Yellow silk / OSP	1
	3	TVS	ZD-1	PTVS28VS1UR	1
	4	Connector	-	AVX_Interconnect-70-9296-001-003-006	4

No	Part	Reference	Specification	Quantity	
XMD-FBB-LLCA	1	LED PKG	D1~D12	DY9560-28(<200mV binning)	12
	2	MCPCB	-	MCPCB 281mm x 19.2mm x 1.6mm (t)/ 1layers / Cu=2oz / White PSR / Yellow silk / OSP	1
	3	TVS	ZD-1	PTVS28VS1UR	1
	4	Connector	-	AVX_Interconnect-70-9296-001-003-006	4

## Marking Information

Fig 1. Marking point

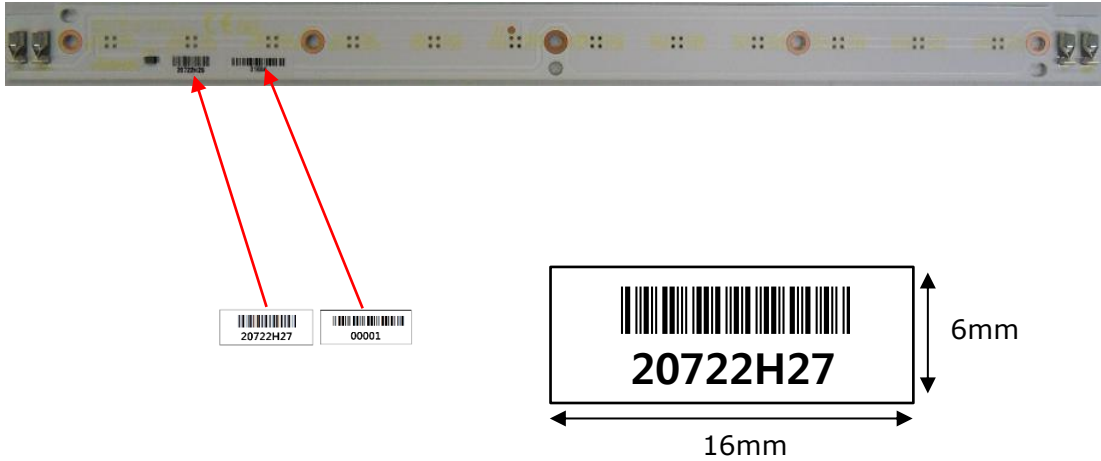
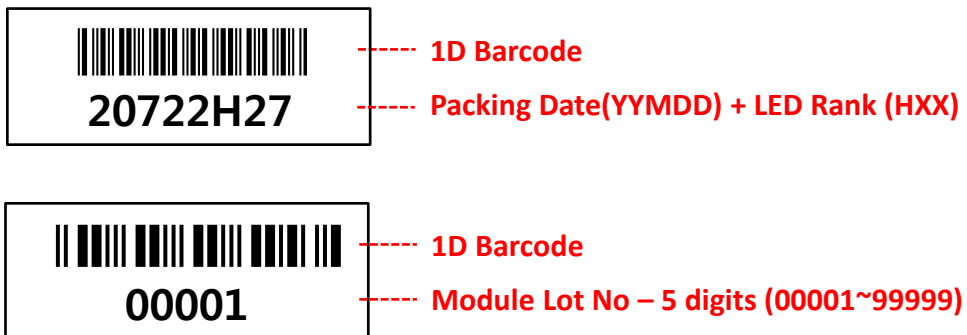



Fig 2. Marking information



### Notes

- 1) Refer to the page 11 for Packing Date

## Label Information

<b>Model No.</b>	<b>XMD-FBx-LLxA<sup>(1)</sup></b> 
<b>Type</b>	
<b>Quantity</b>	<b>XXX</b> 
<b>Lot No.</b>	<b>YYMDDXXXXX-xxxxxxx<sup>(2)</sup></b> 
	<b>SEOUL VIOSYS CO.,LTD</b>

### Reference

- (1) Module part number  
Refer to the page2 for part number selection.
- (2) Box quantity.
- (3) YYMDD : Packing Date
  - YY : last 2digits of year (ex – 2018 → 18)
  - M : Oct-A, Nov-B, Dec-C (1digits)
  - DD : Date (2digits)
  - X : Initial of Manufacturer (1digits)
  - XXXX : Sealing Pack No (4digits)
  - : dash
  - XXXXXXX : SVC Code (7digits)

## Label Information

### ■ Warning Label

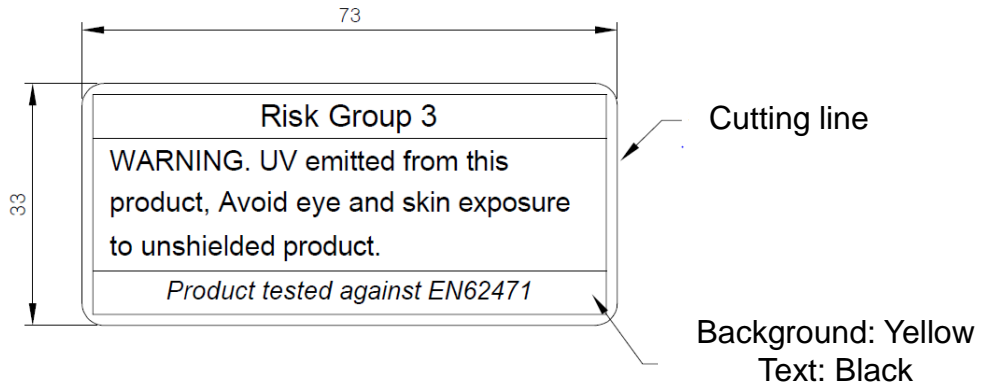

# Packaging Specification

## ■ Packing

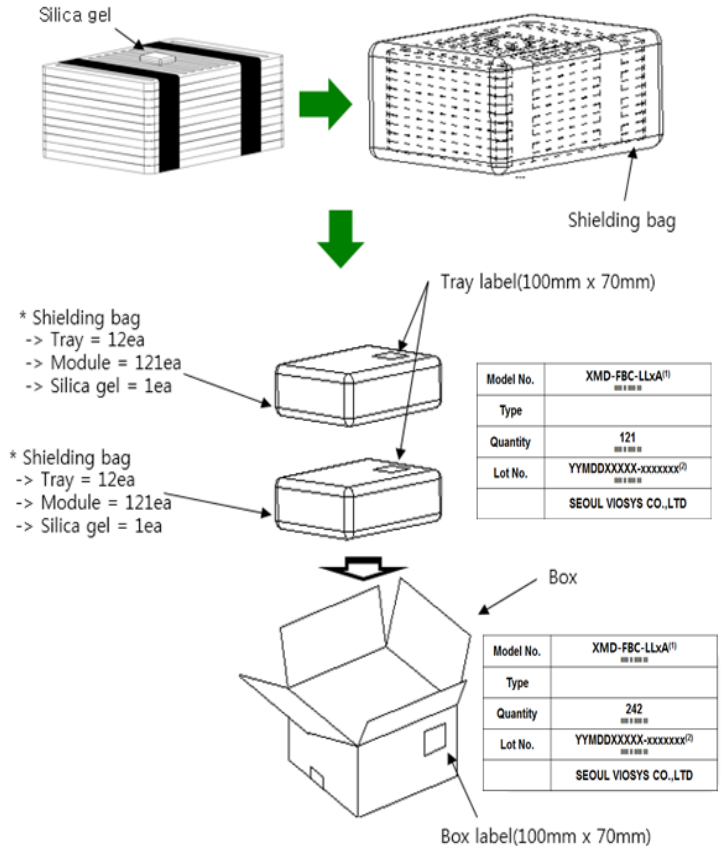
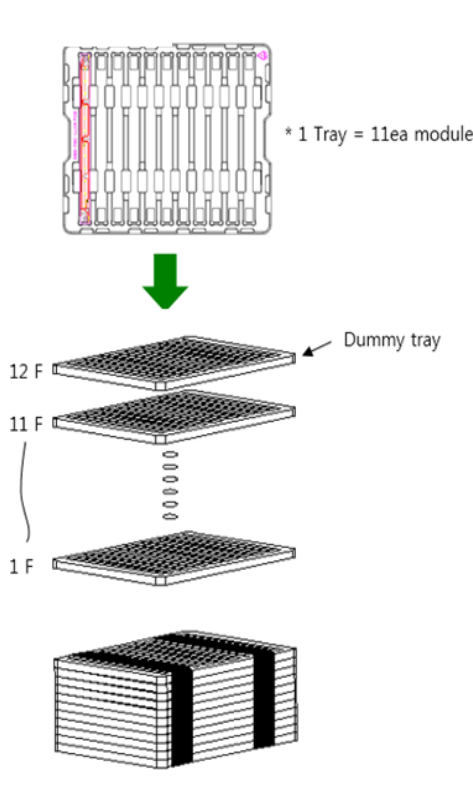

Part	Index	Unit	XMD-FBC-LLxA	Remark
Tray	Size	mm	380 X 315 X 14	
	Module Quantity	ea	11	
	Weight		kg	0.17
		Kg	0.44	With LED module
BOX	Size	mm	407 X 333 X 280	
	Tray Quantity	Ea	22(+2Dummy)	
	Module Quantity	ea	242	
	Material	-	Anti-static PET	
	Weight	kg	10.5	With LED module
Pallet	Size	mm	1100(L) X 1100(W)	
	Box quantity	ea	32	8 Box X 4 Layer
	Weight	kg	5	Only Pallet
Total	Module quantity	ea	7,744	
	Weight	kg	350	With LED module

## Packaging Specification

### ■ Pallet information & packing

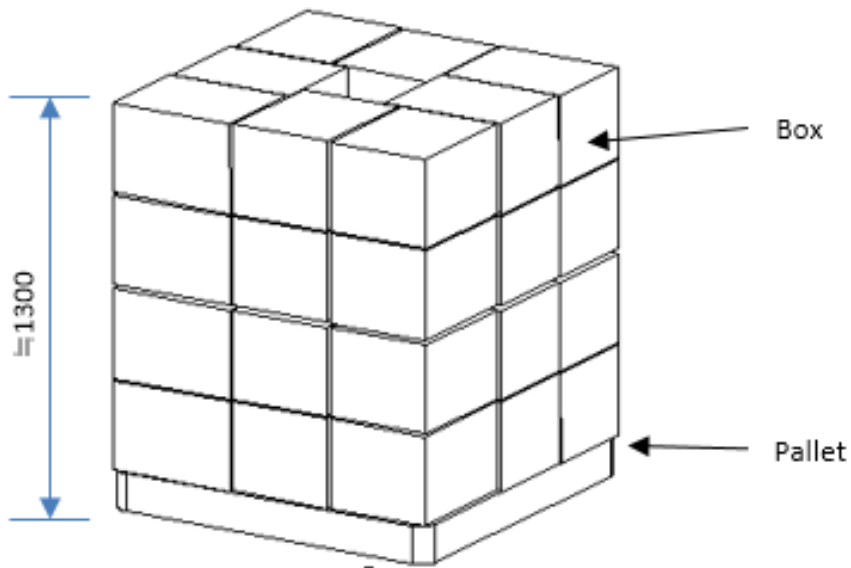

#### Notes

1. The height of the palletization would have to be below 52 inches.
2. Each quantity of boxes for 2 foot and 4 foot are different. Refer to the Quantity information

## Storage before use

- (1) Do not impact or place pressure on this product because even a small amount of pressure can damage the packages.
- (2) When storing devices for a long period of time before usage, please following these guidelines:
  - \* The devices should be stored in the anti-static bag that it was shipped in
  - \* If the anti-static bag has been opened, re-seal preventing air and moisture from being present in the bag.

## Precaution for Use

### A. UV Light

- These devices are ultraviolet LEDs. During operation, the LED emits high intensity ultraviolet (UV) light, which is harmful to skin and eyes. Do not look directly into the UV light and wear protective equipment during operation.
- UV light is hazardous to skin and may cause cancer. Avoid exposure to UV light when LED is operational.
- Precautions must be taken to avoid looking directly at the UV light without the use of UV light protective glasses. Do not look directly at the front of the LED or at the LED's lens when LED is operational.
- **Attach the following warning labels on products/systems that use UV LEDs.**



### B. Static Electricity

- Electrostatic discharge (ESD) is defined as the release of static electricity when two objects come into contact. While most ESD events are considered harmless, it can be an expensive problem in many industrial environments during production and storage. The damage from ESD to an LEDs may cause the product to demonstrate unusual characteristics such as:
  - Increase in reverse leakage current lowered turn-on voltage
  - Abnormal emissions from the LED at low current
- The following recommendations are suggested to help minimize the potential for an ESD event.
- One or more recommended work area suggestions:
  - Ionizing fan setup
  - ESD table/shelf mat made of conductive materials
  - ESD safe storage containers
- One or more personnel suggestion options:
  - Antistatic wrist-strap
  - Antistatic material shoes
  - Antistatic clothes
- Environmental controls:
  - Humidity control (ESD gets worse in a dry environment)



## Precaution for Use

### C. Operating Conditions

- In order to ensure the correct functioning of these LEDs, compliance to the maximum electrical specifications is paramount. These LEDs are particularly sensitive to any current value that exceeds the absolute maximum rating of the product. Any applied current in excess of the maximum specification will cause damage and possible complete failure of the product.
- The current flowing in a LED is an exponential function of the voltage across it. A small change in voltage can produce a very large change in current and lead to complete failure of the LED. The use of current regulated drive circuits are recommended for these products.
- **Any attempt to drive these UV LEDs with a voltage source instead of a current source will cause damage and possible complete failure of the product.**
- These devices are not designed to be used under negative bias.
- This device is not to be used in any type of fluid such as water, oil, organic solvent, etc.
- These LEDs are susceptible to heat generation. Use care to design end product with adequate thermal management to ensure that LEDs do not exceed maximum recommended temperatures. Operating LEDs at temperatures in excess of specification will result in damage and possible complete failure of the product. When the LEDs are in operation the maximum current should be decided after measuring the package temperature.
- The driving circuit must be designed to allow forward voltage only when it is ON or OFF. If the reverse voltage is applied to LED, migration can be generated resulting in LED damage.
- EOS (Electrical Over Stress) – EOS is defined as damage that may occur when an electronic device is subjected to a current or voltage that is beyond the maximum specification limits of the device. The effects from an EOS event can be noticed through product performance like:
  - Changes to the performance of the LED package (If the damage is around the bond pad area and since the package is completely encapsulated the package may turn on but flicker or show severe performance degradation.)
  - Changes to the light output of the luminaire from component failure
  - Components on the board not operating at determined drive power
  - Failure of performance from an entire fixture due to changes in circuit voltage and current across total circuit causing trickle down failures.
- It is impossible to predict the failure mode of every LED exposed to electrical overstress as the failure modes vary significantly, but there are some common signs that will indicate an EOS event has occurred:
  - Damaged may be noticed to the bond wires (appearing similar to a blown fuse)
  - Damage to the bond pads located on the emission surface of the LED package (shadowing can be noticed around the bond pads while viewing through a microscope)
  - Anomalies noticed in the encapsulation and phosphor around the bond wires. This damage usually appears due to the thermal stress produced during the EOS event.

## Precaution for Use

### C. Operating Conditions - Continued

- To help minimize the damage from an EOS event Seoul Viosys recommends utilizing:
  - A surge protection circuit
  - An appropriately rated over voltage protection device
  - A current limiting device

### D. Storage

- To avoid moisture penetration, we recommend storing UV LEDs in a dry box with a desiccant. The recommended temperature and relative humidity are between 5°C and 30°C and below 50% respectively.
- LEDs must be stored properly to maintain the device. If the LEDs are stored for 3 months or more after being shipped from SETI, a sealed container with a nitrogen atmosphere should be used for storage.
- Replace the remained LEDs into the moisture-proof bag and reseal the bag after work to avoid those LEDs being exposed to moisture. Prolonged exposure to moisture can adversely affect the performance of the LEDs.
- If the package has been open for more than 168hr or the color of the desiccant changes, components should be dried for 10-12hr at 60±5°C.
- The conditions of resealing should be as follows: Temperature between 5 and 40°C and relative humidity less than 30%

### E. Handling Precautions

- VOCs (Volatile organic compounds) emitted from materials used in the construction of fixtures can penetrate the LED packages and affect LED performance and lifetime. Knowledge of the properties of the materials selected to be used in the construction of fixtures can help prevent these issues.
- When attaching LEDs, do not use adhesives that outgas organic vapor.
- Do not apply mechanical force or excess vibration during the cooling process to normal temperature after soldering.

### F. Cleaning

- In the event that the surface of the LED requires cleaning, a compressed gas duster or an air gun with 20 psi at nozzle at a distance of 6" away will be sufficient to remove the dust and debris

## Company Information

### Published by

Seoul Viosys © 2013 All Rights Reserved.

### Company Information

Seoul Viosys ([www.seoulviosys.com](http://www.seoulviosys.com)) manufactures light emitting diodes (LEDs) with a full range of UV wavelengths from UVC to UVA (under 400nm) for Industrial Curing, Air/Water Purification, Disinfection and Home appliance.

The company is one of the world leading UV LED supplier, holding more than 4,000 patents globally, while offering various kinds of LED technologies and application-solutions in High power UV LED, UV sensor, UV LED Lamp and variety of UV LED sourced Applications.

The company's broad product portfolio includes hybrid modules for unique applications such as UV disinfection, deodorization, UV purification as well as customized modules for your Application.

### Legal Disclaimer

Information in this document is provided in connection with Seoul Viosys products. With respect to any examples or hints given herein, any typical values stated herein and/or any information regarding the application of the device, Seoul Viosys hereby disclaims any and all warranties and liabilities of any kind, including without limitation, warranties of non-infringement of intellectual property rights of any third party. The appearance and specifications of the product can be changed to improve the quality and/or performance without notice.

## Revision History

Revision	Date	Page	Remarks
Preliminary	5/26/20	All	Preliminary data sheet
1.8	7/29/20		Official Release – packing, marking, certification updates
1.9	12/16/20		CE, UL numbers included